



Dell WM326
Wireless Mouse
User's Guide



Notes, Cautions, and Warnings

-  **NOTE:** A NOTE indicates important information that helps you make better use of your Dell Wireless mouse.
-  **CAUTION:** A CAUTION indicates potential damage to hardware or loss of data if instructions are not followed.
-  **WARNING:** A WARNING indicates a potential for property damage, personal injury, or death.

Copyright © 2015 Dell Inc. All rights reserved. This product is protected by U.S. and international copyright and intellectual property laws.

Dell™ and the Dell logo are trademarks of Dell Inc. in the United States and/or other jurisdictions. All other marks and names mentioned herein may be trademarks of their respective companies.

Contents

What's in the box	4
Features	5
Top View	5
Bottom View	6
Setting up your wireless mouse	7
Dell Universal Receiver Feature for Windows	10
Troubleshooting	11
Specifications	12
General	12
Electrical	12
Physical Characteristics	12
Environmental	12
2.4 GHz wireless	12
Statutory information	13
Warranty	13
Limited Warranty and Return Policies	13
For U.S. customers:	13
For European, Middle Eastern and African customers:	13
For non-U.S. customers:	13
Certifications	14
Microsoft WHQL Logo	14

What's in the box

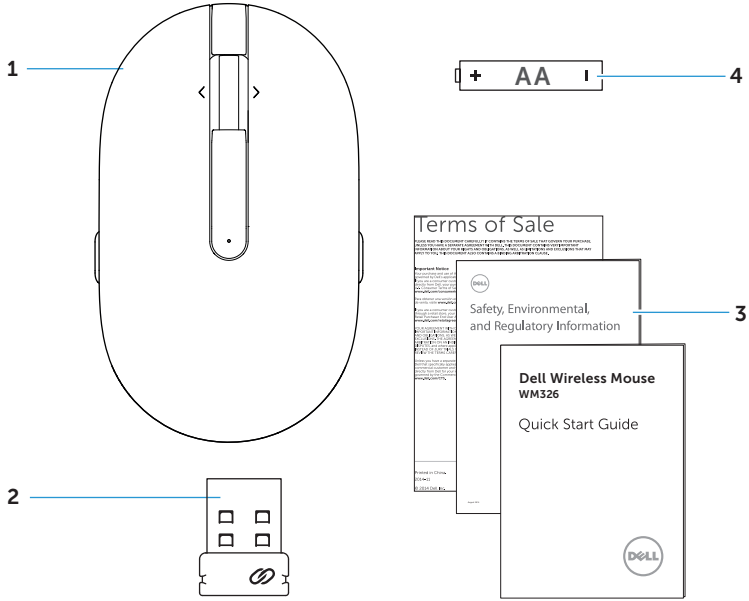

1 wireless mouse

3 documents

2 USB receiver

4 AA-type battery

Features

Top View

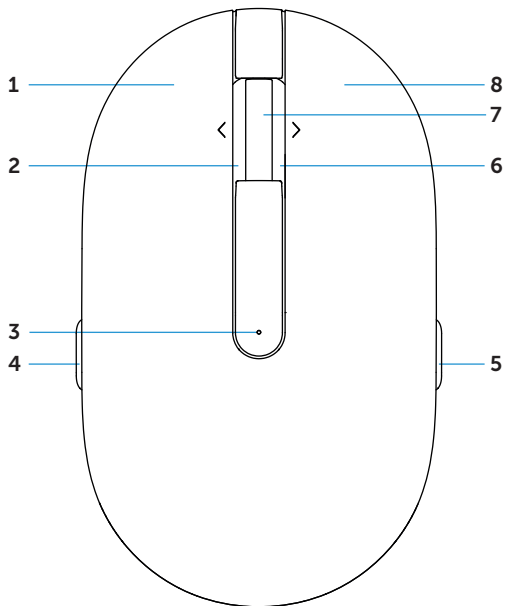

- | | | | |
|---|------------------------|---|------------------------|
| 1 | left button | 2 | side scroll left tilt |
| 3 | battery status light | 4 | page backward |
| 5 | page forward | 6 | side scroll right tilt |
| 7 | scroll / middle button | 8 | right button |

 **NOTE:** When the battery power is low, the battery status light will be solid amber.

Bottom View

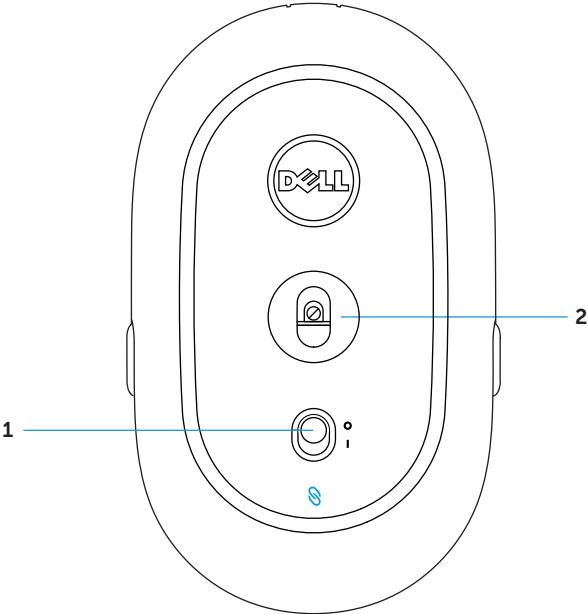

1 power button

2 optical sensor

Setting up your wireless mouse

1. Remove the mouse cover.

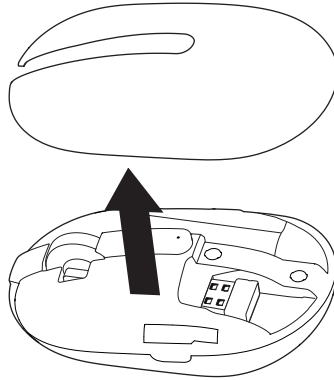

2. Install the AA battery into the battery compartment.

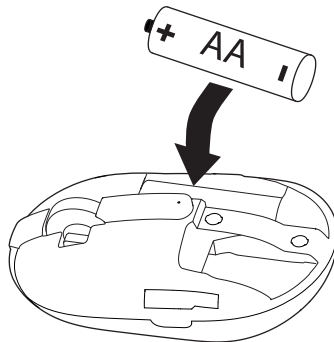

3. Remove the USB receiver.

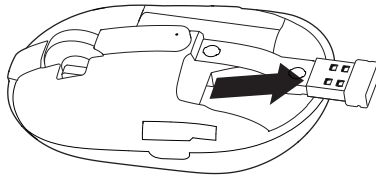

4. Replace the mouse cover.

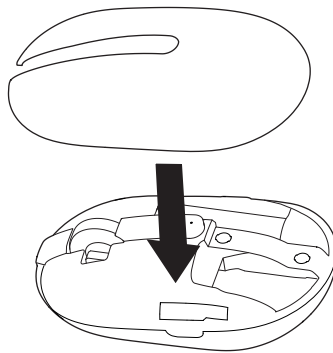

5. Insert the USB receiver into the USB port on your computer.

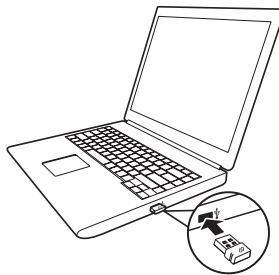

6. Turn on your mouse.

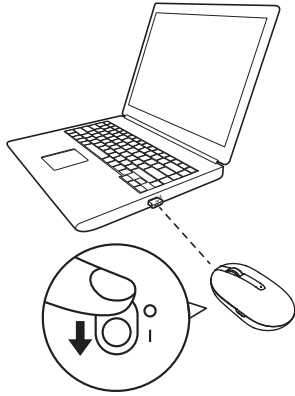

 **NOTE:** Make sure the distance between your computer and mouse is within 10 meters.

Dell Universal Receiver feature for Windows



The Dell Universal Receiver allows up to six Dell Universal compatible wireless devices to be added to the receiver.

Dell Universal Receiver Control Panel

You can add Dell Universal compatible wireless devices to the receiver using Dell Universal Receiver Control Panel.

Installing Dell Universal Receiver Control Panel

To install Dell Universal Control Panel:

1. Turn on the computer.
2. Open the web browser and navigate to **www.dell.com/support**.
3. Type in the Search bar "dell universal receiver". Then click **Search**.



4. Download and install the Dell Universal Receiver software in your system.

Using Dell Universal Receiver Control Panel

The receiver and mouse shipped with your system are paired at the factory. Use the Dell Universal Receiver Control Panel to view the connection status of your wireless mouse or pair the mouse with another receiver.

Follow the instructions on the screen to add a device or to remove pairing.

Troubleshooting

Problems	Possible causes	Possible solutions
Unable to use the mouse	The white LED indicator on the top of the mouse does not light up when the mouse is turned on	<ol style="list-style-type: none">1. Check if the battery is inserted correctly.<ul style="list-style-type: none">• Battery “+” and “-” ends should follow those indicated on the battery compartment label.2. Check the battery level.<ul style="list-style-type: none">• If the mouse uses a rechargeable battery, make sure the battery is fully charged.• If the battery is exhausted, replace it with a new one.3. Turn the mouse off then on.<ul style="list-style-type: none">• Check if the battery status light is flashing amber 10 times, indicating the battery power is low. If the battery is fully depleted, the battery status light will not turn on.4. Make sure the USB dongle is directly connected to your computer.<ul style="list-style-type: none">• Avoid using the port replicators, USB hubs, etc.5. Change the USB port.<ul style="list-style-type: none">• Insert the USB dongle into another USB port on your computer.

Problems	Possible causes	Possible solutions
Mouse pointer does not move	The mouse pointer freezes	<ol style="list-style-type: none"> 1. Check the battery level. <ul style="list-style-type: none"> • If the mouse uses a rechargeable battery, make sure the battery is fully charged. • If the battery is exhausted, replace it with a new one. 2. Turn the mouse off then on. <ul style="list-style-type: none"> • Check if the battery status light is flashing amber 10 times, indicating the battery power is low. If the battery is fully depleted, the battery status light will not turn on. 3. Restart your computer.
Left/right buttons don't work	No response when the left or right mouse button is pressed	
Wireless connection is lost	Previously paired mouse no longer works on the computer	

Problems	Possible causes	Possible solutions
Unable to pair the mouse with the computer	Wireless pairing error message is received while pairing the mouse with the computer	<ol style="list-style-type: none">1. Check the battery level.<ul style="list-style-type: none">• If the mouse uses a rechargeable battery, make sure the battery is fully charged.• If the battery is exhausted, replace it with a new one.2. Turn the mouse off then on.<ul style="list-style-type: none">• Check if the battery status light is flashing amber 10 times, indicating the battery power is low. If the battery is fully depleted, the battery status light will not turn on.3. Restart your computer.4. Make sure the USB dongle is connected directly to your computer.<ul style="list-style-type: none">• Avoid using the port replicators, USB hubs, etc.5. Change the USB port.<ul style="list-style-type: none">• Insert the USB dongle into another USB port on your computer.

Specifications

General

Model number	WM326
Connection type	2.4 GHz wireless technology
System requirement	Microsoft Windows 10/Microsoft Windows 8/ Microsoft Windows 7/Microsoft Windows XP/ Microsoft Windows Vista/ Server 2003/ Server 2008/Server 2012/Linux 6.x, Ubuntu, Neokylin, Free DOS, Chrome and Android

Electrical

Operating voltage	1.0 V - 1.5 V
Battery required	One AA alkaline

Physical Characteristics

Weight (without battery)	62.1 g (0.137 lb)
Dimensions	
Length:	101.7 mm (3.335 in)
Width:	60.3 mm (1.977 in)
Height:	35.5 mm (1.164 in)

Environmental

Temperature	
Operating:	-10°C to 50°C
Storage:	-40°C to 65°C
Storage Humidity	95% maximum relative humidity; non-condensing

2.4 GHz wireless

Radio transmission	Bi-directional communication (Transceiver)
Range	Up to 10 m

Statutory information

Warranty

Limited Warranty and Return Policies

Dell-branded products carry a 1-year limited hardware warranty.

For U.S. customers:

This purchase and your use of this product are subject to Dell's end user agreement, which you can find at <http://www.dell.com/terms>. This document contains a binding arbitration clause.

For European, Middle Eastern and African customers:

Dell-branded products that are sold and used are subject to applicable national consumer legal rights, the terms of any retailer sale agreement that you have entered into (which will apply between you and the retailer) and Dell's end user contract terms.

Dell may also provide an additional hardware warranty – full details of the Dell end user contract and warranty terms can be found by going to <http://www.dell.com>, selecting your country from the list at the bottom of the "home" page and then clicking the "terms and conditions" link for the end user terms or the "support" link for the warranty terms.

For non-U.S. customers:

Dell-branded products that are sold and used are subject to applicable national consumer legal rights, the terms of any retailer sale agreement that you have entered into (which will apply between you and the retailer) and Dell's warranty terms. Dell may also provide an additional hardware warranty – full details of Dell's warranty terms can be found by going to <http://www.dell.com>, selecting your country from the list at the bottom of the "home" page and then clicking the "terms and conditions" link or the "support" link for the warranty terms.